

Sept 2020

INSTALLATION METHODOLOGY FOR FLOORFLEX & SUPERFLEX VINYL TILES

GENERAL

The final appearance and durability of any resilient flooring installation depends largely on the condition of the surface upon which it is laid. A good concrete sub-floor is the result of sensible planning, careful design and detailing, adequate specifications, good workmanship and proper inspection.

All resilient flooring materials require a smooth, hard, clean and level surface, not only for appearance but also for achieving a satisfactory adhesive bond and long-term durability. Any traces or patches of oil, grease or any oil-based paint must be removed from the sub-floor surface. This can be done using either paint strippers or degreasing compounds. Once clean the sub-floor must be thoroughly washed to remove any stripper or residue and then allowed to dry thoroughly.

RESPONSIBILITY

The specifier and main contractor shall ensure that the sub-floor is acceptable to receive the resilient flooring specified in respect of levelness, smoothness, soundness and cleanness, with a minimum requirement of a Grade 1-floor finish as set out in SANS 10070. This finish is generally achieved with a high-quality, reliable self-levelling cementitious compound.

The flooring contractor shall also ensure that the sub-floor is sufficiently dry prior to the installation of the flooring material. All sub-floors should be tested for dryness by using a suitably approved Concrete Moisture Meter. (*Tramex CME 4, Romus/Caisson VI-D4 Pinless Concrete Moisture Meter, GE Protimeter Mini or a Hygrometer*).

MATERIAL SPECIFICATION

Floorflex Tiles

Supply and fix 1.6mm/2.0mm/2.5mm thick x 300mm x 300mm Floorflex semi-flexible vinyl tiles manufactured in accordance with SANS 581 and laid in FloorworX No. 62 acrylic adhesive which has been spread using a trowel fitted with an A2 notched blade at a rate of between 5.5m² and 6.5m² per litre on a previously prepared Class 1 subfloor in accordance with SANS 10070, using a reliable Self Leveller when required, including all cutting and waste. The flooring must be rolled in both directions with an articulated 68kg three-sectional roller immediately after it has been laid into the adhesive. The newly laid floor must, after 48 hours, be stripped using FloorworX Stripper, scrubbed using a diluted solution of FloorworX Rinse and then sealed with 3 coats of FloorworX Silk Matt or Gloss Sealer.

Superflex Tiles

Supply and fix 2.0mm/2.5mm thick x 300mm x 300mm Superflex fully flexible vinyl tiles, manufactured in accordance with SANS 786 and laid in FloorworX No. 62 acrylic adhesive which has been spread using a trowel fitted with an A2 notched blade at a rate of between 5.5m² and 6.5m² per litre on a previously prepared Class 1 sub-floor in accordance with SANS 10070, using a reliable Self-Leveller when required, including all cutting and waste. The flooring must be rolled in both directions with an articulated 68kg three-sectional roller immediately after it has been laid into the adhesive. The newly laid floor must, after 48 hours, be stripped using FloorworX Stripper, scrubbed using a diluted solution of FloorworX Rinse and then sealed with 3 coats of FloorworX Silk Matt or Gloss Sealer.

An Accéntuate Limited Company

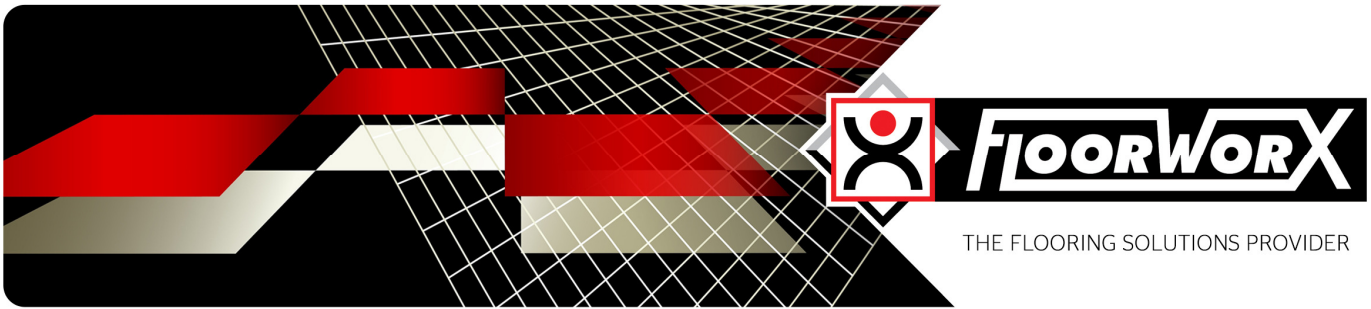

APPLICATION

Ensure that all recommendations for substrate and job site conditions are met before beginning the installation. Beginning the installation is an implied acceptance of site conditions by the parties involved and liability for any failure directly related to inadequate site conditions becomes the responsibility of the installer and/or flooring contractor.

Note - Sub-floor temperature should not be less than 6°C or more than 27°C.

ADHESIVE RECOMMENDATIONS AND APPLICATION

Floorflex and Superflex Tiles should be laid in FloorworX No 62 water-based acrylic adhesive which has been spread using a trowel fitted with an A2 notched blade at a rate of approximately 5.5 to 6.0m² per litre (depending on the porosity of the floor).

Note the following:-

- Trowels will wear during use, check the trowel both before and during use to ensure that the proper, specified trowel notch is used and maintained.
- The adhesive must be spread evenly over the entire floor area with particular attention to edges – this will ensure that the product is fully bonded at the perimeters.
- Ensure that the material is rolled immediately afterwards with a 68 kg articulated roller, rolling in all directions to ensure a firm bond. It is important to only spread sufficient adhesive that can be covered within the open* time of the adhesive.
- Areas that cannot be rolled with the large roller e.g. abutments such as door frames or skirting boards should be rolled with a hand roller.
- Always clean away excess adhesive with a damp cloth before it is allowed to dry.

(See **FloorworX Technical Bulletin No. 35: Floorworx Adhesives and their Applications**).

*The open time of the adhesive will depend on site conditions and porosity of the substrate. It is best practice to conduct an adhesive bond test before starting the installation, as this will assist in identifying both the working characteristics of the adhesive (waiting and working time) for the site conditions and also any potential bonding problems. When the adhesive feels tacky but not wet, the flooring can be laid. Ensure that the flooring is laid into the adhesive before it dries.

Note:-

- If the flooring is laid into the adhesive too early, the volatiles which have not flashed off will be trapped. This will prevent the adhesive from curing and will result in a poor bond. The problem will manifest itself in the peaking or lifting of the flooring.
- If the flooring is laid into the adhesive too late, there will be little or no bond which will result in the flooring lifting. Trowel notch marks will show through the flooring once it has been trafficked.

MATERIAL

- Prior to installation, the tiles should be checked to ensure that the correct colour, batch number, and quantity have been received and that the material is in good condition.
- Only use material from the same batch/dye lot. (The use of different production batches will always result in visible shade differences. The batch numbers are marked on the box and must be checked before the commencement of the installation).

- **Boxes must not be stored more than 5 high**, as this will result in distortion and potential damage.
- Any uncertainty surrounding quality-related matters must be clarified with the *FloorworX* Technical Department, as **claims will only be considered if less than 100 sqm are laid before the complaint has been reported.**

1. SETTING OUT THE INSTALLATION

The floor should be swept or preferably vacuumed, to remove all dust and dirt.

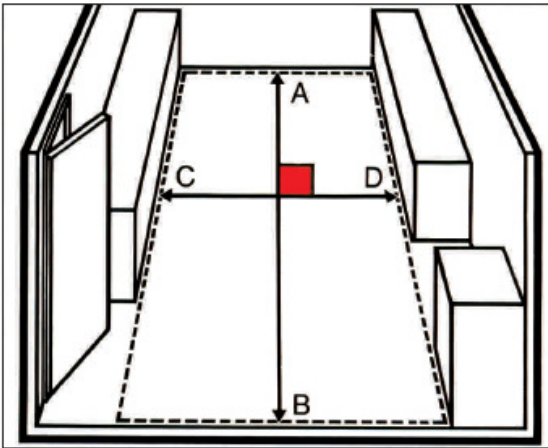

Fig.1

1.1 To obtain the best results, laying should commence from the centre of the floor. Strike a chalk line parallel to the longest wall, **A-B** along the centre of the sub-floor. Strike a second chalk line at right angles to the first, **C-D**.

1.2 Check that the border tiles to be “cut-in” around the perimeter of the floor are at least half a tile wide.

Refer to Fig 1

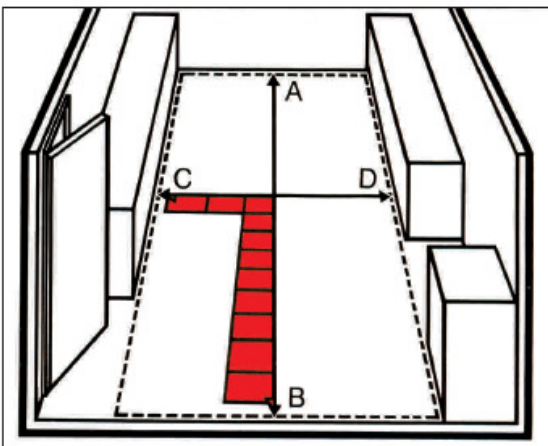

Fig 2

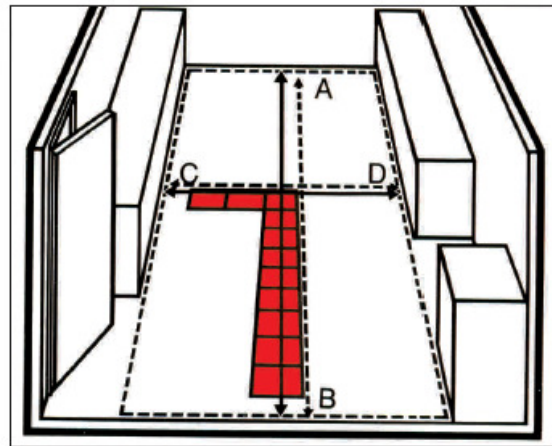

Fig 3

1.3 If the gap between the wall and the last full tile is less than half a tile in width, mark a new chalk line parallel to the original chalk line **A-B**, one half tile width away. **Refer to Fig 2.**

1.4 Repeat step 1.3 with the other wall and mark a new chalk line parallel to the original **C-D**. **Refer to Fig 3**

1.5 Check the chalk lines are square with each other. In a small area use a set square to check, but in a large area make use of the 345 method as shown below. **Refer to Fig 4.**

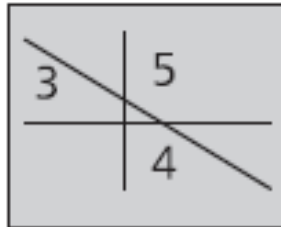

Fig 4

2. APPLYING THE ADHESIVE

2.1 Read the instructions on the drum of the adhesive.

2.2 Pour sufficient adhesive onto the sub-floor to cover a reasonable area. (If too large an area of adhesive is spread, the adhesive will dry before the tiles can be laid).

2.3 Using a (TKB – A2) notch trowel, spread the adhesive over both chalk lines leaving a part of each line uncovered at either end. The two quarters to be covered (spread) with adhesive. Once an area has been covered with the adhesive, the chalk lines must be re-marked, using the position of the line left exposed.

2.4 Spread the adhesive evenly. Do not leave bare spots, pools or overlapping ridges of adhesive. Lightly touch the spread adhesive, when no wet adhesive transfers to the fingertip, the adhesive will be ready and the flooring can be laid. This normally takes between 15 and 25 minutes depending on ambient temperatures.

2.5 Place the first tile carefully at the intersection of the two chalk lines. **Refer to Fig 5.**

2.6 Place successive tiles outwards from the first and along both chalk lines building a “castle”. Lay each tile with the “grain” (marbling) at right angles (tessellated) to the adjacent tile. **Refer to Fig 6 & 7.**

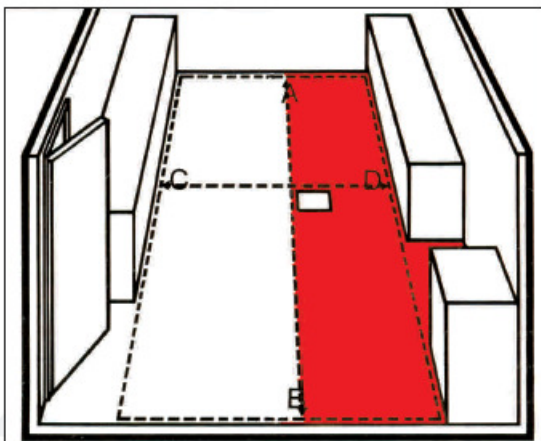

Fig 5

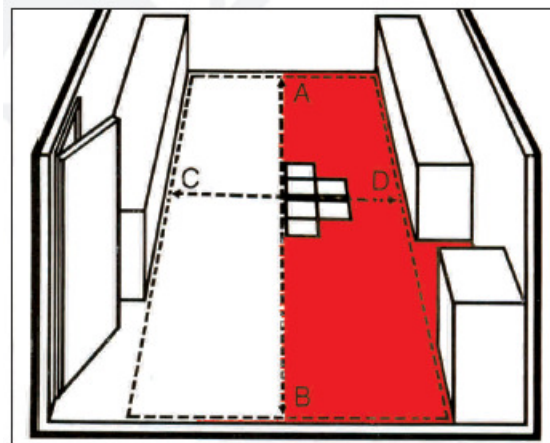
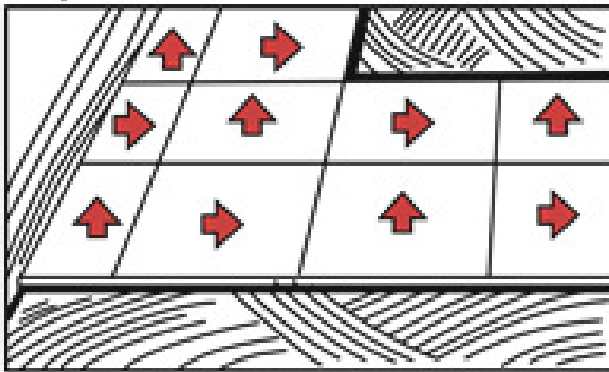

Fig 6



2.7 Ensure that the tiles' edges are firmly butted against the adjoining tile.

The material can be installed in either a **tessellated, monolithic or brick bond** configuration.

A tessellated formation should be used for the best aesthetic result. It is however advised that the configuration at all times needs to conform to the specification or clarified with the customer/client before the material is installed.

Fig 7

2.8 Ensure that any excess adhesive is removed using a clean damp rag.

2.9 Continue laying the tiles until reaching the border where tiles must be "cut-in".

2.10 To "cut-in" border tiles, place a tile (A) exactly on top of the last full tile closest to the wall, ensuring that the grain (marbling) is in the correct direction for the border tile. Refer to Fig 7.

2.11 Place another tile (B) right against the wall and on top of tile (A). Refer to Fig 8.

2.12 Using the edge of the tile "B", mark or score a line on tile (A). Cut tile (A) along the mark and install as the border tile. Refer to Fig 9.

NB: When "cutting-in" border tiles, ensure that the adhesive has not dried. (The adhesive should not have been spread for more than about 45 minutes.)

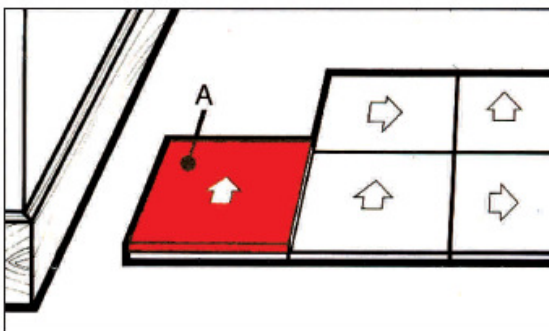

Fig 7

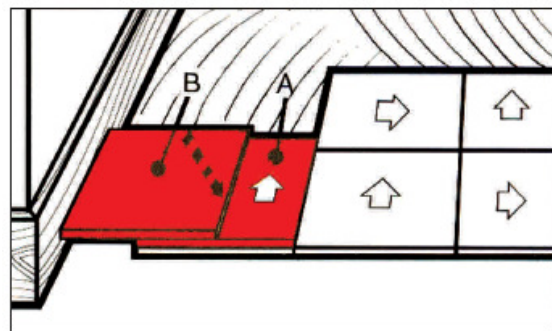

Fig 8.

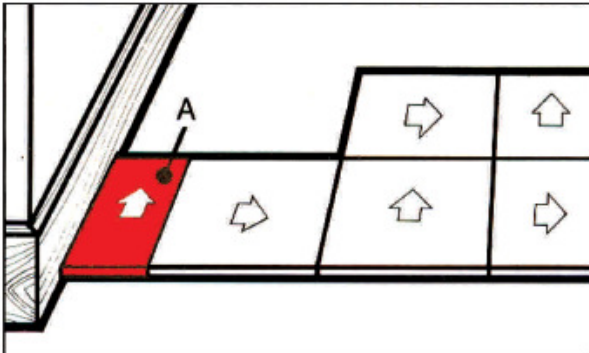

Fig 9

2.13. The installed flooring must be rolled in both directions with a 68-kilogram three-sectional articulated metal flooring roller, **within the working time of the adhesive.**

2.14. It is vitally important that after installation the flooring should be adequately protected, preventing damage caused by other trades working on the site.

2.15. **Maintenance.** The completed floor should not be washed or cleaned for 48 hours after completion of the installation, to allow sufficient time for the adhesive to cure properly. This period will vary from one adhesive to another. Avoid excessive use of water at all times as this will have a detrimental effect on the adhesion of the tiles to the sub-floor and could cause the tiles to peak at the joints. It is recommended that the product is sealed with an acrylic emulsion (FloorworX Sealer) for further protection and a proper maintenance regime implemented. It may be advisable to appoint a company specialising in floor care to carry out the respective maintenance procedures.

FLOORWORX AFRICA (PTY) LTD MANUFACTURE TOP QUALITY FLOORING PRODUCTS - IF YOU ARE DISSATISFIED WITH A FLOORWORX PRODUCT, CONSULT YOUR DEALER OR CONTACT THE NEAREST BRANCH OF FLOORWORX.